



SCD5745-IGV V1

Double-Sided 57.4" Resizing LCD, 1000 nits LED backlight, 3840 x 807 ultra-wide aspect ratio 16:3.4

The SCD5745-IGV is a 57.4" double sided LCD display with special aspect ratio 16:3.4, wide resolution 3840 x 807 and high brightness 1000 nits. This ruggedized outdoor unit is design for street level with IP54 waterproof and build in high performance computer to delivery information message and advertising content. SCD5745-IGV is a true plug & play solution that includes everything required for outdoor displays including the computer, WiFi connectivity and resistant glass.

Key Features

- Double-sided 57.4" resizing LCD
- Ultra-Wide Screen (16: 3.4)
- High Brightness 1000 nits
- High Efficiency LED Backlight
- 4mm Thick Resistant Glass
- IP54 Environmental Rating
- Intel® Skylake-U Series Processor
- Storage SSD 64GB
- BL MTBF: 100,000 hours



Specifications

Model Name	SCD5745-IGV V1
Description	Double-Sided 57.4" Resizing LCD, 1000 nits LED backlight, 3840x807
Screen Size	57.4"
Display Area (mm)	1428.5(H) x 300.2(V)
Brightness	1000 cd/m ²
Resolution	3840x807
Aspect Ratio	16 : 3.4
Contrast Ratio	5000 : 1
Pixel Pitch (mm)	0.374(H) x 0.374(V)
Pixel Per Inch (PPI)	67
Viewing Angle	178°(H), 178°(V)
Color Saturation (NTSC)	82%
Display Colors	1.07G
Response Time (Typical)	9.5ms
Computer	Intel® Skylake-U Series Processor
Storage	SSD 64GB
Memory	DDR4 SO-DIMM 4GB
Wi-Fi	Intel Dual Band Wireless AC-8260
IEEE WLAN Standard	IEEE 802.11 a,b,g,n,ac
OS	Win 10 (64 bit), Win 8/8.1 (64 bit), Win 7 (32/64 bit), Ubuntu 16.04 (64 bit)
SCD5745-IGV-M01	Windows 10 (64 bit)
SCD5745-IGV-M02	None
Connector	M12, AC Power input
Resistant Glass	4mm Thick
Glass Treatment	AR Coating
Waterproof	IP54
Input Power	AC100~240V



Power Consumption	243W
Panel	196W
Computer	47W (Burn-in Test/Light Loading)
Outline Dimensions (mm)	1552 x 413 x 402.1
Weight (Net)	99 kg
Operating Temperature	0 °C ~ 50 °C
Storage Temperature	-20 °C ~ 60 °C

Specifications are subject to change without notice.

All brands or product names are trademarks or registered trademarks of their respective companies.



Mechanical Drawing

Outline Dimensions

Unit: mm

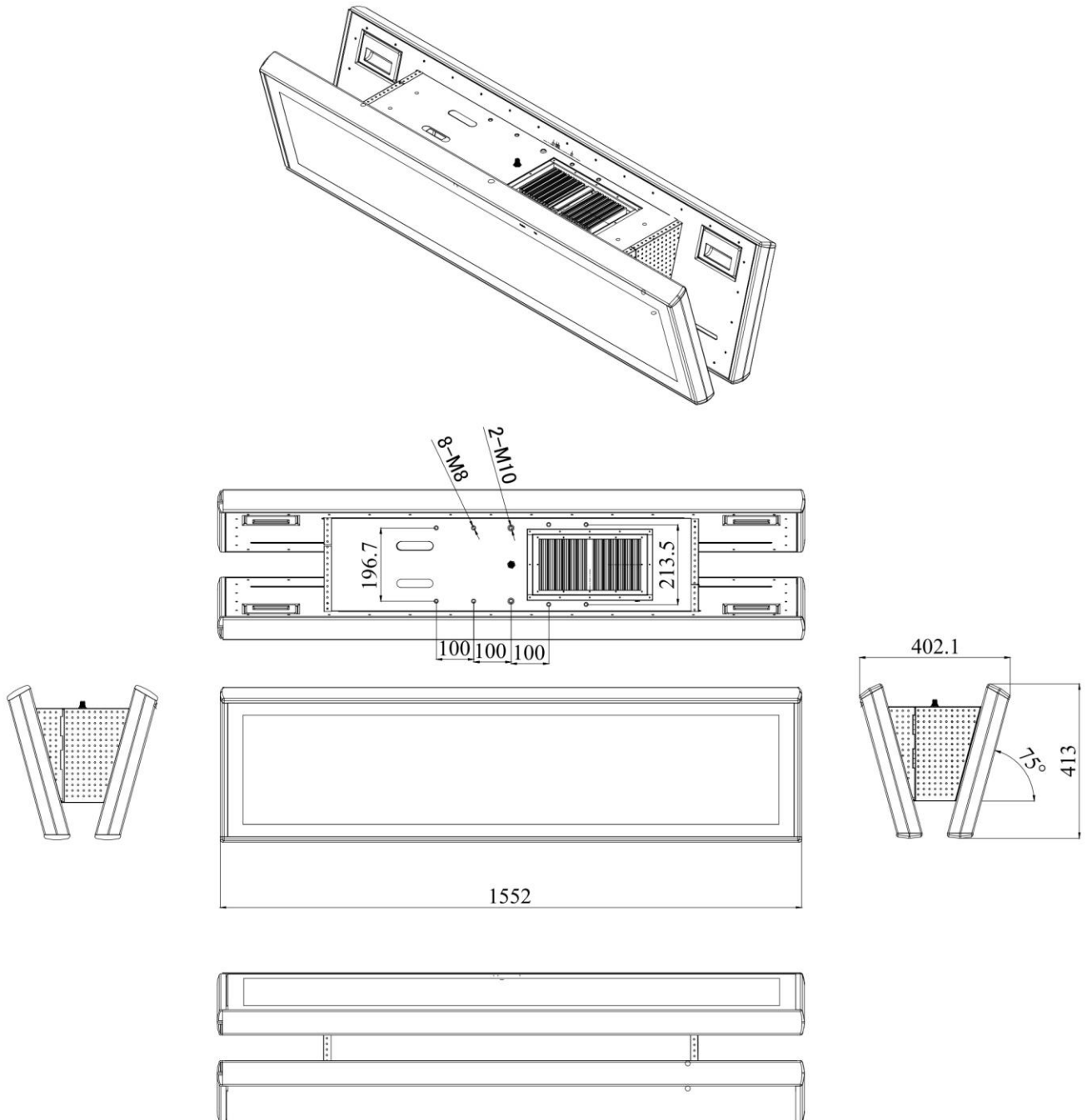

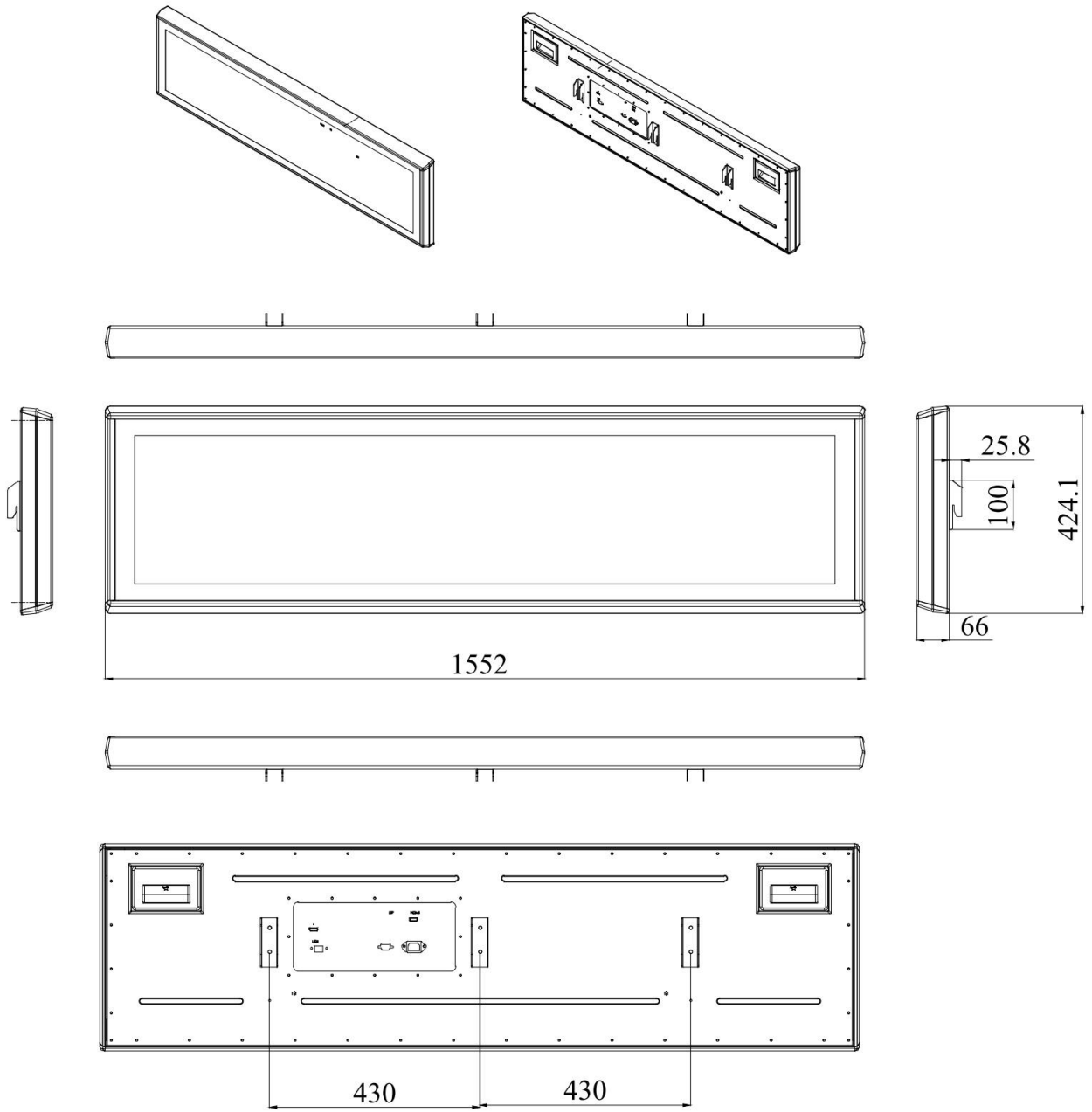

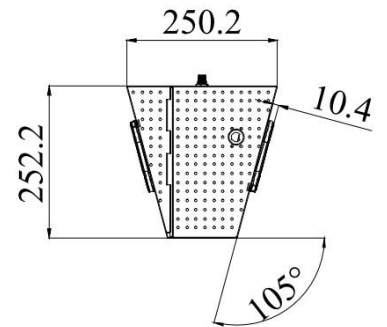
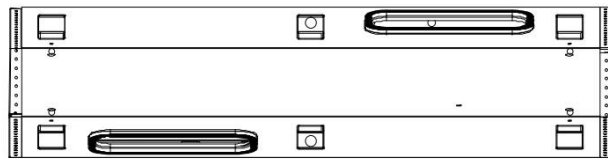
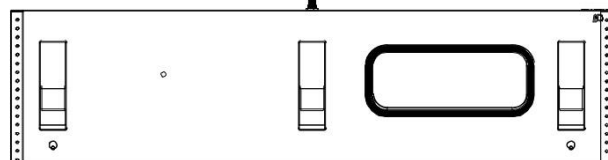
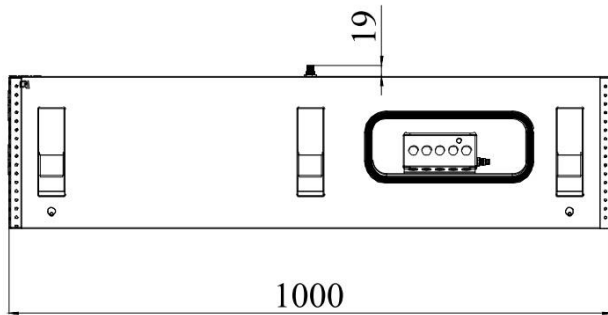
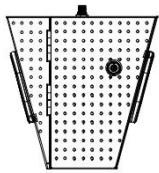
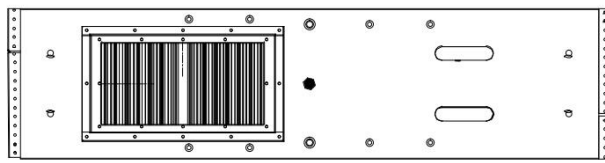
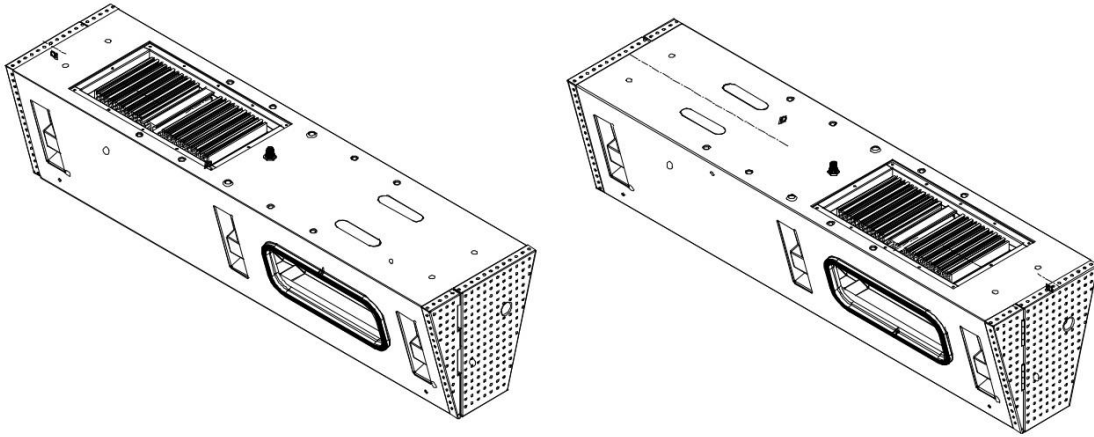



Ordering Information

Part Number	Description
SCD5745-IGV-M01	57.4"x2,1000nits,3840*807,V Shape,4mm AR Glass(T=90%),IP54,M12,IBOC-SKL2-6300-Z000-0001,DDR4 4GB,SSD 64GB,Wifi, w/win10 IOT,AC100~240V,V1
SCD5745-IGV-M02	57.4"x2,1000nits,3840*807,V Shape,4mm AR Glass(T=90%),IP54,M12,IBOC-SKL2-6300-Z000-0001,DDR4 4GB,SSD 64GB,Wifi, w/o OS,AC100~240V,V1

Optional Accessories

Part Number	Description
98000860011	Power Cable,M12 Connector,Open Terminal,L=500mm

By Customer Request

Touch	PCAP Touch
--------------	------------